

41) 1028-80
33

0071

International Standard



2861 / 2

INTERNATIONAL ORGANIZATION FOR STANDARDIZATION • МЕЖДУНАРОДНАЯ ОРГАНИЗАЦИЯ ПО СТАНДАРТИЗАЦИИ • ORGANISATION INTERNATIONALE DE NORMALISATION

Vacuum technology — Quick release couplings — Dimensions — Part 2 : Screwed type

Technique du vide — Raccords rapides — Dimensions — Partie 2 : Raccords de type fileté

First edition — 1980-08-01

Вакуумная техника. Быстроразъемные соединения. Размеры. Часть 2. Соединение винтового типа.

182

UDC 621.643.4 ~~1028-80~~

Ref. No. ISO 2861/2-1980 (E)

Descriptors : vacuum technology, vacuum apparatus, pipe joints, vacuum seals, threaded mechanical parts, O-ring seals, dimensions, pipe clips.

Price based on 6 pages

ISO 2861/2-1980 (E)

Foreword

ISO (the International Organization for Standardization) is a worldwide federation of national standards institutes (ISO member bodies). The work of developing International Standards is carried out through ISO technical committees. Every member body interested in a subject for which a technical committee has been set up has the right to be represented on that committee. International organizations, governmental and non-governmental, in liaison with ISO, also take part in the work.

Draft International Standards adopted by the technical committees are circulated to the member bodies for approval before their acceptance as International Standards by the ISO Council.

International Standard ISO 2861/2 was developed by Technical Committee ISO/TC 112, *Vacuum technology*, and was circulated to the member bodies in December 1978.

It has been approved by the member bodies of the following countries :

Belgium	Italy	Spain
Chile	Korea, Rep. of	Turkey
Czechoslovakia	Mexico	United Kingdom
France	Netherlands	USSR
Germany, F.R.	Romania	
India	South Africa, Rep. of	

The member bodies of the following countries expressed disapproval of the document on technical grounds :

Australia
Poland
USA

Vacuum technology — Quick release couplings — Dimensions — Part 2 : Screwed type

1 Scope and field of application

This part of ISO 2861 specifies the dimensions of quick-release couplings of the screwed type as used in vacuum technology, as well as those of the "O" rings and the insert which are associated with these tailpieces to ensure coupling tightness.

General information is also included which refers to the clamped quick-release coupling standardized internationally in ISO 2861/1, with which the screwed quick-release coupling specified in this part is compatible.

2 Designation

Each quick-release coupling of the screwed type shall be designated by its nominal bore and a reference to this part.

3 Screwed coupling tailpiece

Figure 1 illustrates the form of the screwed coupling tailpiece. All associated dimensions are given in table 1.

4 Screwed coupling insert

Figure 2 shows the screwed coupling insert. The associated dimensions are given in table 2.

5 "O" ring seal

The "O" rings are illustrated in figure 3 and associated dimensions are given in table 3. The nominal hardness recommended for the "O" ring is 65° Shore

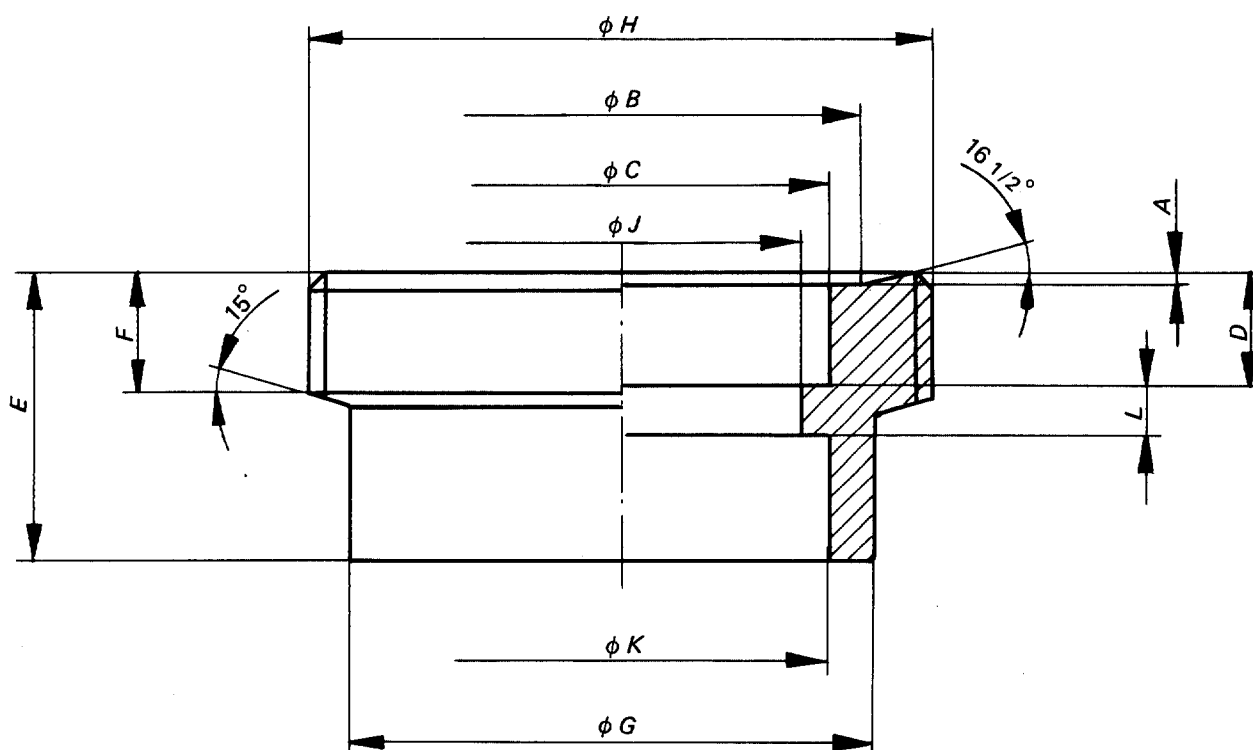

Figure 1 – Tailpiece

NOTE – A surface finish of at least $1,6 \mu\text{m}$ for the sealing surface has proved satisfactory in practice.

Table 1 – Dimensions of tailpiece

Values in millimetres

Nominal bore	A h11	B j_s13	C B11	D	E min.	F	G max.	H	J	K B11	L	Tube outside diameter ¹⁾
10	0,9	17,5	15,0	6	16	7,5	18	G1B	13	14,0	4	14,0
16	0,9	22,5	20,0	6	16	7,5	23	G1B	18	20,0	4	20,0
25	1,15	31,0	28,0	6	19	7,5	32	G11/4B	26	28,0	7	28,0
40	1,15	46,0	42,5	6	22	7,5	46	G2B	40	42,5	10	42,4

1) These values are given for guidance only.

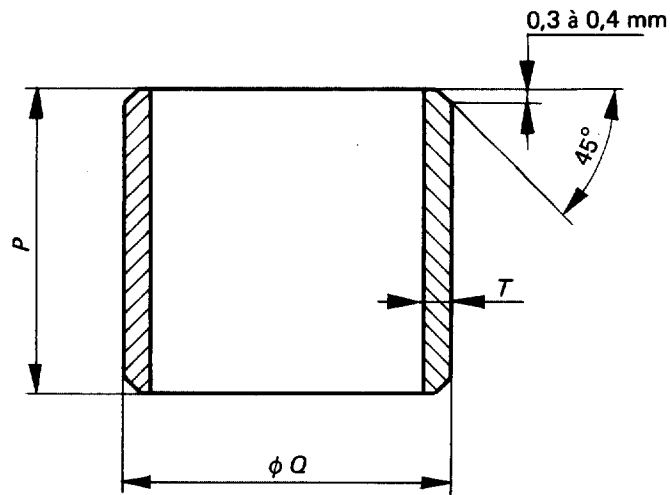

Figure 2 – Insert

Table 2 – Dimensions of insert

Values in millimetres

Nominal bore	P	Q $j_{5,6}$	T min.
10	11,0	14,9	0,5
16	11,0	19,9	0,75
25	11,0	27,9	0,75
40	11,0	41,9	1,00

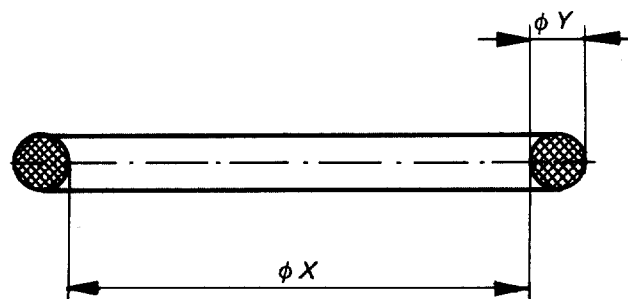

Figure 3 – "O" ring

Table 3 – Dimensions of "O" ring

Values in millimetres

Nominal bore	X	Y
10	14,6	2,4
16	19,6	2,4
25	27,5	3,0
40	41,5	3,0

Annex A

Clamped quick-release couplings

The figures illustrate the general form. Dimensions are given in ISO 2861/1.

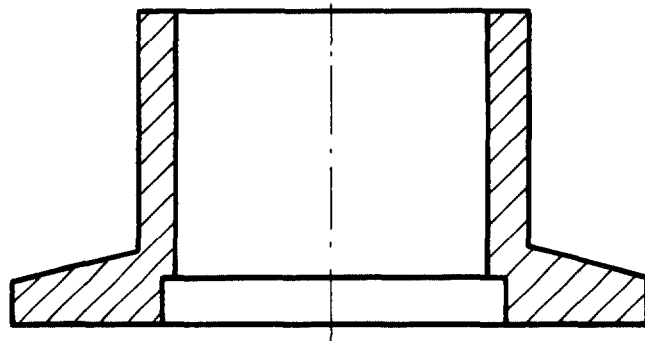

4a) – Tailpiece

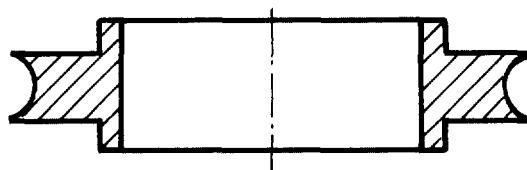

4b) – "O" ring carrier



4c) – "O" ring

Figure 4 – Clamped quick-release coupling components

Annex B

Assembly of clamped and screwed quick-release couplings

B.1 Screwed quick-release coupling

The method of assembling the mating parts of the quick-release coupling is shown in figure 5.

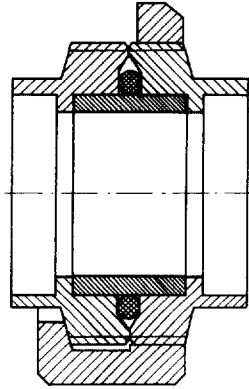

Figure 5 – Assembly of screwed quick-release coupling

B.2 Clamped quick-release coupling

The method of assembling the mating parts of the quick-release coupling is shown in figure 6.

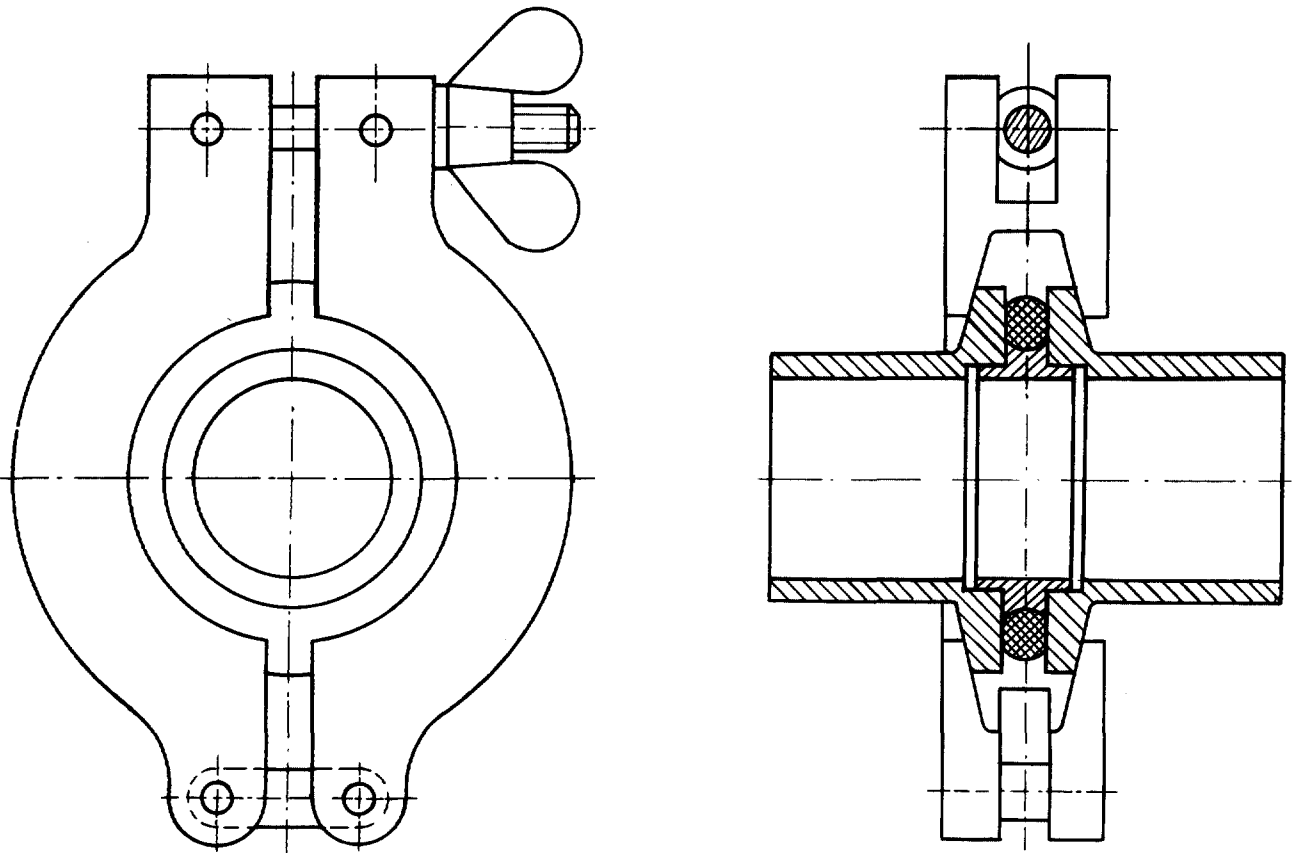

Figure 6 – Assembly of clamped quick-release coupling

B.3 Screwed-to-clamped quick-release couplings

The screwed quick-release coupling tailpiece may be directly connected to the clamped quick-release coupling tailpiece as shown in figure 7.

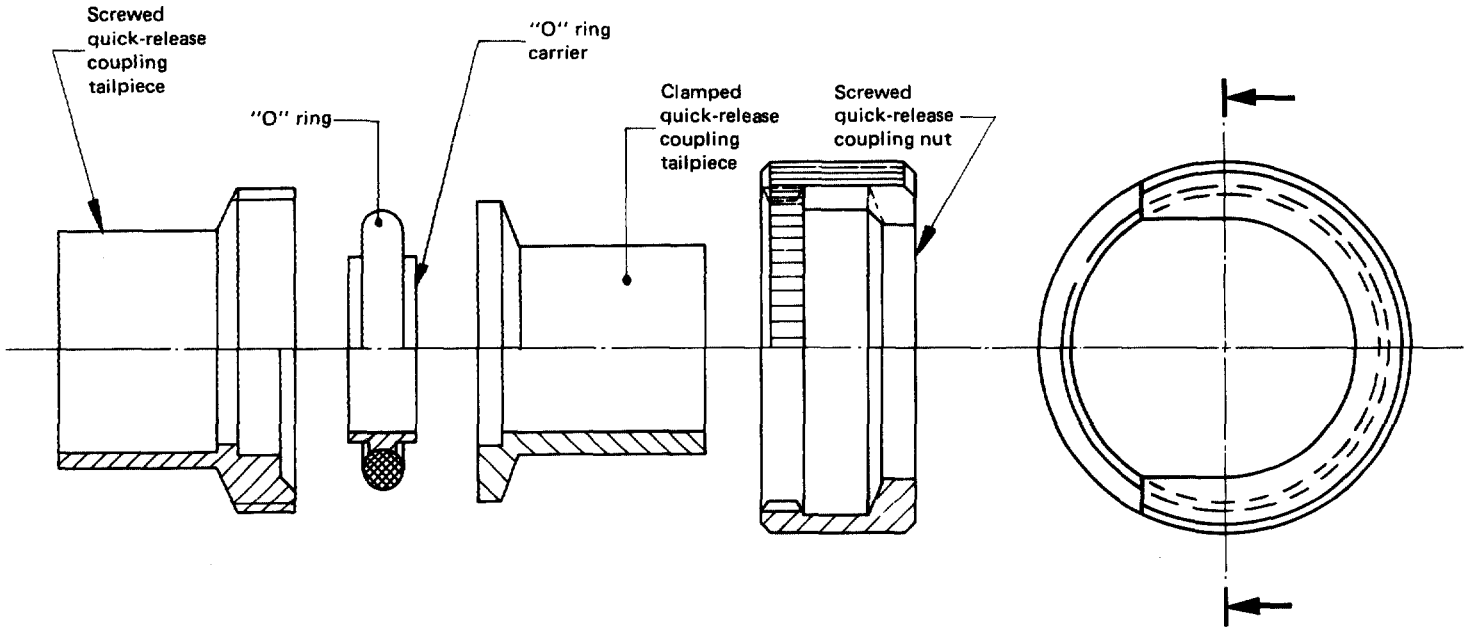

Figure 7 – Assembly of screwed-to-clamped quick-release coupling

1. Армаатура трубопроводов